

## I. KEEP TANK CLEAN

For best results it is recommended that the Tank be thoroughly cleaned frequently. This removes dirty gasoline, water and residue which would otherwise stop up the Vaporizer and cause difficulty in operation.

Your burner will light easier and better on fresh gasoline.

If the burner is to be stored away or not used for sometime all fuel should be removed from Tank by allowing burner to burn out of fuel.

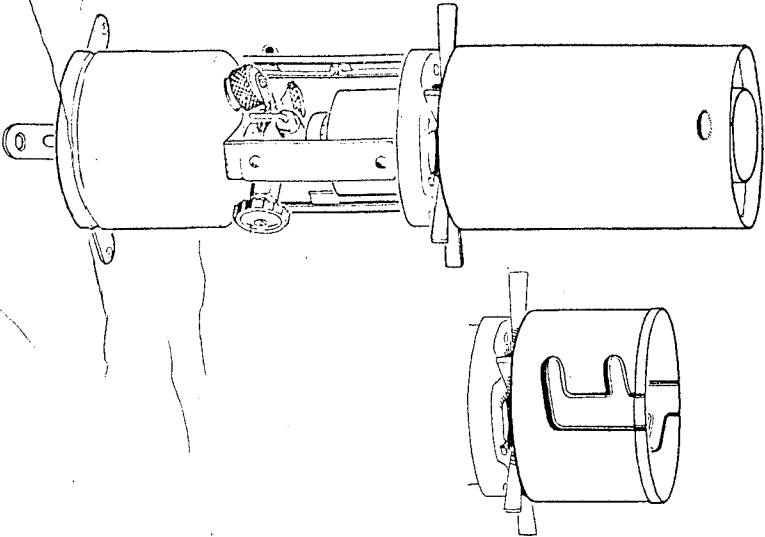

## SUGGESTIONS

### About Care and Use of Coleman Military Burner Model 520

#### A. If Flame Burns Yellow

**CAUSE:** Carbon or gum bridging across outside of Vaporizer Gas Tip.  
**REMEDY:** Remove Burner Head and scrape off carbon. Carbon building up on under side of burner plate.  
**REMEDY:** Use sharp instrument and scrape off carbon from underside. See paragraph "H".  
**CAUSE:** Vaporizer stopped up with dirt or carbon.  
**REMEDY:** Remove Vaporizer and clean as instructed in paragraph "G".  
**CAUSE:** Burner Head loose on Vaporizer.  
**REMEDY:** Tighten firmly.

#### B. If Burner Does Not Burn At All

**CAUSE:** No fuel, lack of air pressure.  
**REMEDY:** See that Tank contains clean fuel and then pump in 30 to 35 strokes of air into Tank.  
**CAUSE:** Vaporizer stopped up.  
**REMEDY:** Clean Vaporizer. See paragraph "G".

#### C. If Vaporizer Lasts Only a Short Time

**CAUSE:** May be dirt from gasoline or loose carbon in the Vaporizer.  
**REMEDY:** Clean Tank and Vaporizer thoroughly — strain gasoline when filling Tank.

#### D. If Built-in Pump Does Not Work

**CAUSE:** Pump Leather may be dry.  
**REMEDY:** Remove Pump Plunger and soften Pump Leather with oil.  
**CAUSE:** Pump Leather worn out.  
**REMEDY:** Put in a new Pump Leather.  
**CAUSE:** Plunger in Check Valve is stuck.  
**REMEDY:** Remove the Pump Plunger. Insert screw driver in the Pump Barrel and unscrew, then remove the Check Valve. Wash Check Valve thoroughly in gasoline and replace. If the Pump still does not work, replace the Check Valve with a new one.

## TWO THINGS

### TO DO WHICH WILL HELP THIS COLEMAN MILITARY BURNER GIVE YOU BETTER SERVICE AND LONGER SERVICE

1. Always use a good grade of fresh, clean gasoline. Use non-leaded gasoline when available. Burns leaded gasoline satisfactorily; however, adequate ventilation must be provided to avoid harmful effects from lead fumes.
2. Read and carefully follow instructions given in this Direction Folder. If you will do this, you will avoid difficulties that result from improper operation and which are due to no fault of the product.

Order by Number	Name of Part	Net Retail Price
104-147	Lock Nut	\$0.00
118 B 430	Filter Plug Gasket	00
118 B 430	Filter Plug Packing	00
216-509	Paint Penetrating	00
242-353	Tip Cleaner Stem Complete	21
242 B 538	Check Valve	21
520-148	Fuel and Air Wire Complete (Fuel Tip Marked "O")	39
520-210	Red Lock Nut	09
520-218	Gas Tip (Marked "V")	09
520-246	Valve Wheel	05
520-251	Cleaner Rod and Needle	21
520-259	Filter Screen	18
520-289	Vaporizer (Gas Tip Marked "V")	18
520-304	Eccentric Block	06
520-309	Preheater Cup	18
520-325	Burner Head Complete	09
520-423	Utility Cup	15
520-424	Utility Cup	15
520-432	Utility Bar	07
520-435	Utility Bar, Double	07
520-457	Cotter Key	03
520-475	Frame Assembly	75
520-476	Pump Plunger Complete	66
520-532	Pump Air Stem	18
520-532	Valve Stem Complete	160
520-657	Fuel Valve Complete	5 45
520-950	Wrench	21
520A140	Filter Plug Complete	54
520A165	Tank Assembly	450
523-472	Spare Parts Holder	30
605-616	Lock Nut	15

"Prices Subject to Change Without Notice"

### WARNING

For Longest Service... For Best Service Use Only Genuine Coleman Parts and Accessories on this Coleman Appliance. Each individual part is designed to exact precision and to work perfectly with all other parts; therefore, only Genuine Coleman Parts and Accessories can be trusted to give satisfactory service. The use of other than Genuine Coleman Parts and Accessories invalidates the Coleman Guarantee.

### Parts List for Coleman Military Burner Model 520

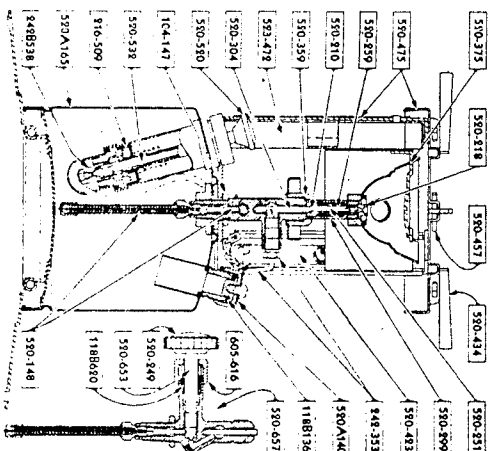

# OPERATING DIRECTIONS

for

# Coleman MILITARY BURNER

Model 520

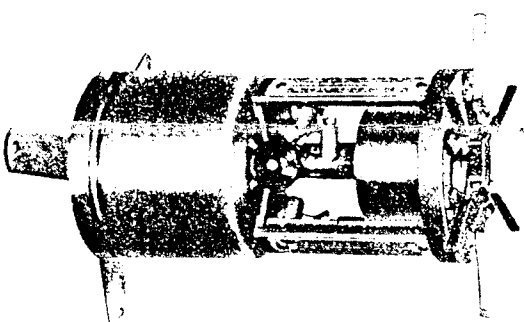

Made in the United States of America

### The Coleman Lamp and Stove Company

General Office and Factory: WICHITA, KANSAS, U.S.A.  
 Canadian Office and Factory: Toronto, Canada.  
 Sales Offices: Chicago, Philadelphia, Los Angeles, Honolulu, Hawaii.

F1228D

Printed in U.S.A.

# OPERATING DIRECTIONS

For

## Coleman MILITARY BURNER

### Model 520

Carefully follow these directions and you will experience no difficulty in operating your new Coleman Military Burner.

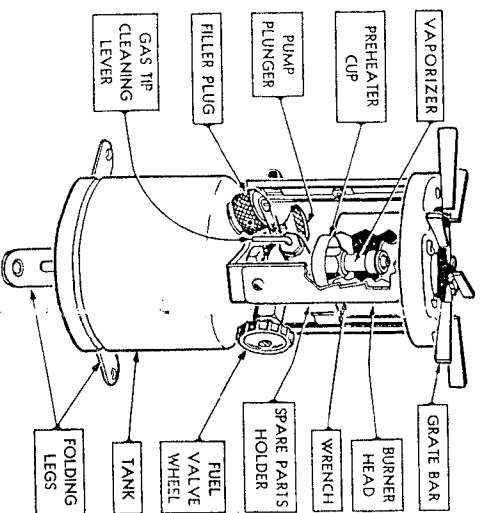

#### A. TO SET-UP BURNER

Remove Utility Cup.  
Turn Grate Bars out to make full sized grate. Turn the Legs in the base out to give a greater base area.

#### B. TO FILL

Be sure Fuel Valve is tightly closed. Turn the Valve Wheel to the right.

Remove Filler Plug and fill Tank with fresh clean gasoline. Use Non-Leaded Gasoline when available. Burns leaded gasoline satisfactorily, however adequate ventilation must be provided to avoid effects from lead fumes.

Do not tip Burner while filling. Always set it flat on its base. We suggest the use of the Coleman No. 0 Filtering Funnel for straining the gasoline.

As soon as Tank is filled, replace Filler Plug Cap and tighten firmly with fingers.

#### C. TO PUMP AIR PRESSURE

See that Fuel Valve is closed, then turn Pump Handle to left two turns. Hold thumb or palm of hand over vent hole in end of Pump Handle and pump 25 to 30 full strokes of air into the Tank. Turn Pump Handle to right to close. Additional pressure should be added later while burner is generating. Keep Pump Leather soft with a few drops of oil.

#### D. TO LIGHT

**First** — Clean Gas Tip in Vaporizer by revolving, several times, the Cleaner Needle Lever located above the Valve. Stop Lever in DOWN position.

**Second** — Open Fuel Control Valve a quarter turn to left. After a few seconds apply lighted match at top of Burner Head. In extremely low temperatures allow Burner Head to become moist with gasoline before applying lighted match. 5 to 10 minutes are required for complete generation.

Under some conditions flame may blow itself out. Just re-light. Flame will soon settle down to steady blue.

Several strokes of the Pump must be added to replace air used in generation.

**Third** — After flame burns steady blue for 2 or 3 minutes, open Fuel Control Valve AS FAR AS POSSIBLE.

#### E. TO SHUT OFF BURNER

Close Fuel Control Valve.

**Note:** Any open burner should never be used in a confined space without ventilation, especially when leaded gasoline is used as fuel.

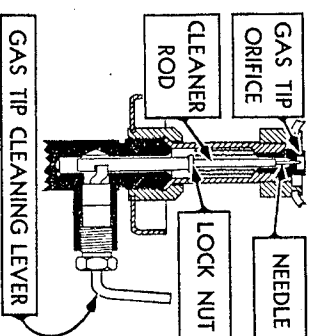

#### F. TO CHANGE CLEANER ROD AND NEEDLE

Turn Tip Cleaner Lever up and loosen Lock Nut at base of Cleaner Rod then unscrew rod to left. The new Cleaner Rod and Needle can now be put in and adjusted to the proper length. Be sure and lock in place after adjustment is made by using Lock Nut from old stem. When Tip Cleaner Lever is turned up the Needle should come through the Gas Tip orifice about  $\frac{1}{2}$  but should not extend above the top of Gas Tip. Do not try to service a bent or otherwise damaged Needle. (See illustration above for correct position of Needle).

#### G. TO CHANGE VAPORIZER

The length of time a Vaporizer can be used without cleaning or replacement is determined by the type of fuel used. When gasoline is vaporized and burned, a residue of carbon is formed from the gum content of the fuel. If anti-knock compound (lead) is added to gasoline, a residue of BOTH carbon and lead will accumulate in the Vaporizer. The use of regular (unleaded) gasoline will greatly increase Vaporizer life. Anti-knock gasoline can be successfully used; however, more frequent cleaning or replacement of the Vaporizer will be required.

Remove the Burner Head by unscrewing to the left.

When loosening the Jam Nut at the base of the Vaporizer — hold the Valve Body so that it will not be loosened in the Tank.

#### TO CLEAN VAPORIZER

Remove Filler Screen and scrape all carbon from inside of Vaporizer. Do not force anything of opening. If a new Filler Screen is available, insert in Vaporizer tube; however, old screen may be cleaned and reused if care is used in unrolling and re-rolling. Screen must be rolled tightly around Cleaner Rod before being put back into Vaporizer to insure proper lighting.

Care must be taken not to damage the needle when reassembling Vaporizer over the Needle.

#### H. KEEP BURNER CLEAN

To clean Burner Plate:

**First** — Unscrew and remove the Burner Head.

**Second** — Insert a sharp stick or wire through the hole in the bottom of the Burner Head to clean or scrape carbon accumulations off the underside of the Burner Plate.

**Third** — Replace and tighten firmly on the Vaporizer.

IT IS IMPORTANT that the underside of the Burner Plate be cleaned frequently or every few days. Failure to do this regularly will reduce the efficiency of the Burner.

