

3. KEEP VALVE PACKING NUT TIGHT—

After the Lantern has been in use for a period of time the Valve Stem Packing may shrink, allowing a slight leak at that point. To eliminate leak, tighten Pack Nut a few turns to hold Packing in firm contact with Valve Stem. Note: If Pack Nut is drawn up too tightly Valve will not turn. Back off slightly. Replace Packing if leak is not stopped by tightening Pack Nut.

4. TO CHANGE GENERATOR—

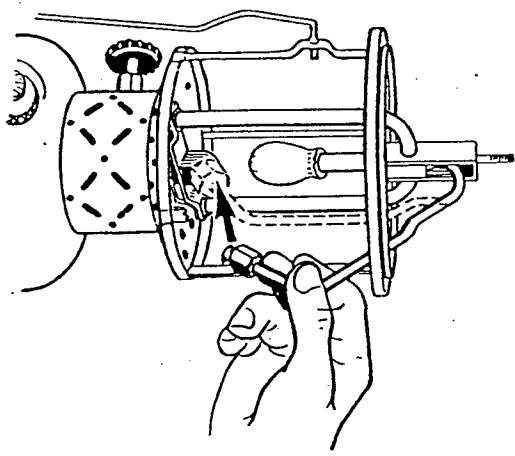

To clean Generator Tip remove Generator Lock Nut and Generator Tube. A cleaning needle is attached to the Wrench which fits into the bottom of the Globe Cage held in place by a Spring. Push Needle through hole in Generator Tip to clean.

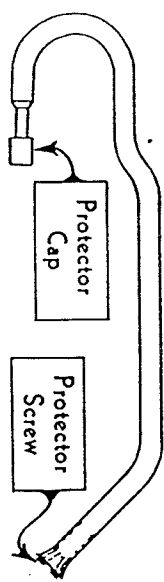

IMPORTANT: Before replacing with new Generator, be sure the protecting cap (on discharge end of Generator) is removed; also remove the protecting screw at the bottom end of Generator.

Care should be exercised in starting the Generator Lock Nut to eliminate the possibility of cross threading. Tighten the Lock Nut as much as possible with fingers; then tighten firmly with Wrench. **Important:** Hold Generator in correct position while tightening Lock Nut to avoid twisting the Generator.

ORDER BY NUMBER	NAME OF PART	QUARTER MASTER STOCK NUMBER
021A306	(21A) Mantle	31-M-500
118B1361	Gasket (Filler Plug)	31-C-40
118B620	Packing (Valve Stem)	33-P-3900
216-509	Leather (Pump)	31-L-750
216-532	Air Stem	
216-538	Valve (Check)	
220B4231	Ball	
220B498	Frame & Ball	31-F-105
220B619	Disc. (Direction)	
252-6571	Valve Ass'y	31-V-150
479-131	Plug (Filler)	31-C-63
252A2101	Nut (Jamb)	31-N-700
252A2991	Generator	31-G-103
252-4421	Ball (Nut)	
252-485	Ventilator	
252-5201	Plunger Ass'y (Pump)	31-P-1425
252-6531	Stem (Valve)	31-S-175
252A9051	Pricker	31-P-1475
252B950	Wrench with Pricker	31-W-500
407-6491	Wheel (Valve)	31-K-750
690-048	Pyrex	31-G-365

DIRECTIONS

for

Operating

INSTANT-LIGHTING LANTERN

No. 252A



The Coleman Company, Inc

General Office and Factory: WICHITA 1, KANSAS, U. S. A.
 Canadian Office and Factory: Toronto, Canada
 Sales Offices: Philadelphia 8; San Francisco 3; Los Angeles
 Honolulu, Hawaii

TO FILL —

This lantern has been designed to operate successfully with leaded motor gasoline. However, where a white first-run gasoline or aviation gasoline is available, these fuels will give better performance than the lantern than it is possible to obtain from the use of leaded motor gasoline. Avoid using any gasoline that has been stored for a long time, as when stored for a long time, gasoline develops aummy, resin-like sediment that will give great difficulty when used in any lantern.

Be sure Fuel Valve is tightly closed to right. Remove Filler Plug and fill Fount. Do not tip lantern while filling. Replace Filler Plug and tighten firmly with fingers (do not use wrench or pliers).

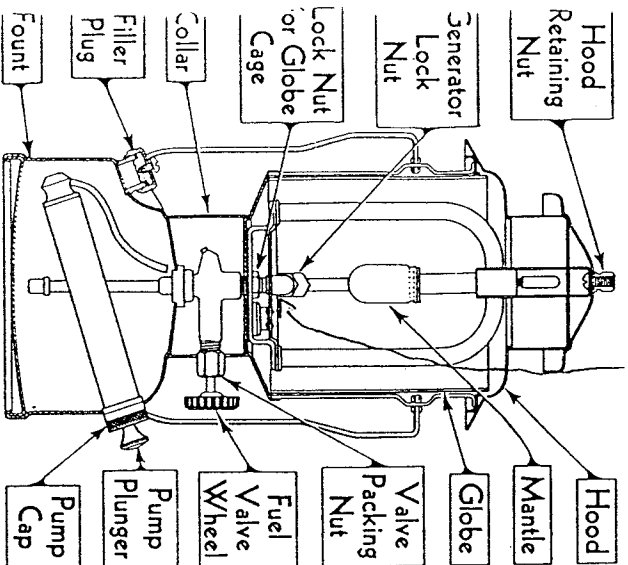

1. TO PUMP —

See that Fuel Valve is closed. Open Air Check Valve inside Pump Barrel) by turning Pump Plunger two full turns to the left. Place ball of thumb over small hole in end of Pump Plunger and pump at least twelve (12) full strokes of air into the Fount. Now turn Pump Plunger to right, seating Air Stem in Check Valve. Remove thumb, push Pump Plunger back into the Pump Barrel. Note: Good pressure is important. Keep Pump Leather soft with a few drops of oil.

3. TO PUT ON MANTLE —

Unscrew Hood Retaining Nut (save for reuse) on top of Lantern and remove Hood and Globe.

The Mantle to groove in Burner Cap. Distribute folds of Mantle evenly at top and cut off surplus strings. Apply flame of match to Mantle and allow Mantle to burn until only a chemical ash remains. Allow Mantle to cool several minutes before lighting Lantern.

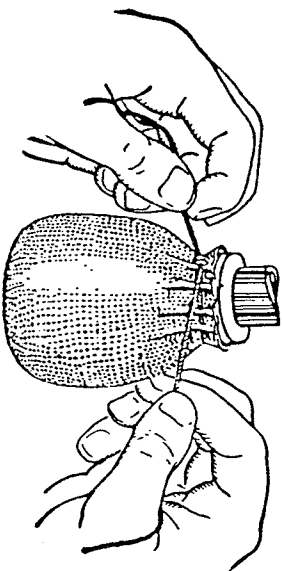

To replace a broken Mantle, follow the instructions given above for putting on a new Mantle, but before putting on this second Mantle it may be necessary to clean the Manifold Tube which supports the Burner Head, due to the possible deposit on the inside of this tube of a yellow lead oxide dust from the lead in the gasoline. This Manifold Tube may be easily cleaned either by inserting a pencil or small stick, running it up and down inside the tube in the same way a ramrod may be used to clean a gun barrel.

4. TO LIGHT —

(a) Hold flame of wood match below Mantle. Immediately open fuel valve ONE-FOURTH TURN. THIS IS IMPORTANT—OPEN IT ONE-FOURTH TURN ONLY. It may require a few seconds for the gas to reach the Mantle, but when it does, Mantle will light instantly.

(b) After the Mantle burns bright, open Fuel Valve as far as possible, which is about three full turns. IT IS IMPORTANT THAT THE FUEL VALVE IS OPENED AS FAR AS POSSIBLE IN ORDER TO MAINTAIN A GOOD LIGHT. It is impossible to open Fuel Valve too far.

(c) After opening Fuel Valve as far as possible, pump in additional pressure to insure long operation.

5. TO TURN OUT LIGHT —

Turn Fuel Valve to right until closed. The light will dim and go out in a few seconds.

SPECIAL PRECAUTION: Always provide good ventilation, particularly when burning leaded gasoline.

Maintenance Suggestions

1. KEEP FOUNT CLEAN —

It is a good plan to drain the fount each time before refilling. THE FOUNT SHOULD BE GIVEN A THOROUGH CLEANING AT LEAST TWICE A MONTH. By cleaning the Fount thoroughly, dirty gasoline and sediment are removed, thus prolonging the life of the Generator.

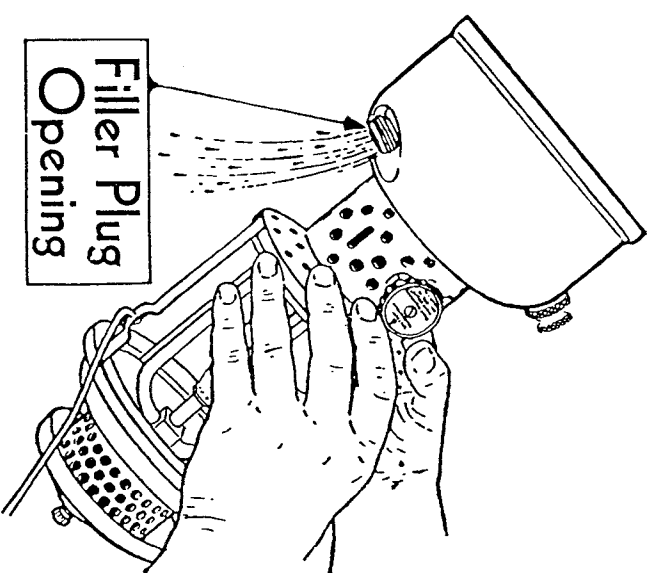

To drain, simply remove Filler Plug and pour gasoline out through Filler Plug opening. The Lantern will light more easily and better with fresh gasoline in the Fount. Whenever available, clean water-white undoped gasoline should be used; however, leaded gasoline and regular motor fuel can be used. **CAUTION:** Always provide good ventilation—particularly when burning leaded gasoline.

2. GOOD PRESSURE IS IMPORTANT —

To insure proper performance of the Pump, the Leather should be kept well oiled to prevent hardening. To oil Leather, unscrew the Pump Plunger Cap and draw the Pump Plunger out until the Leather is visible (it is not necessary to completely remove the Pump Plunger). Oil Leather with a light lubricating oil and replace and tighten Pump Plunger Cap.