

## FOUR THINGS

**TO DO WHICH WILL HELP THIS COLEMAN INSTANT-LIGHTING LANTERN GIVE YOU BETTER SERVICE AND LONGER SERVICE**

1. Always use a good grade of fresh, clean, water-white gasoline. Do not use any of the doped, anti-knock or Ethyl gasolines in this appliance.
2. Ask your dealer or write to your NEAREST Coleman Branch for the latest Approved Fuel List, which lists fuels suitable for use in Coleman Gasoline Pressure Appliances and are obtainable in your state.
3. Read and carefully follow instructions given in this directions folder. If you will do this, you will avoid difficulties that result from improper operation and which are due to no fault of the Lantern.
4. Keep the fount of the Lantern clean. This prevents the residue which may collect at the bottom of the fount from stopping up the generator (see Par. 7).

This Directions Folder is Written for Your Convenience. It is Worth While To Follow Instructions Carefully Step by Step.



## ALWAYS USE GENUINE COLEMAN JUNIOR MANTLES

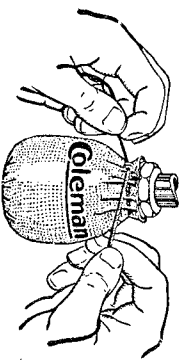

1. They are made without side seams and are pleated or gathered across the bottom, thus reinforcing them at the point where they are subjected to the greatest gas pressure.

2. They are made especially for Coleman Lamps and Lanterns. They are just right in size, shape and texture. They are given just the right chemical treatment. They work perfectly with the gas tip and air intake in producing the splendid brilliance for which the Coleman Lamps and Lanterns are famous.

We cannot guarantee either the quality or quantity of light produced by any Coleman Lamp or Lantern if an inferior low-grade mantle is used on it. So take no chances. Always insist on Genuine Coleman Mantles.

For maximum life and lowest cost service we recommend our Heavy Duty Grade A Silk Late Mantle No. 21A.

## SUGGESTIONS

About Care and Use of Coleman Instant-Lighting Lantern Model 228D

### A. IF LANTERN BLAZES UP AND SMOKES WHEN YOU LIGHT IT—

CAUSE—Lighting Lantern in half-hot condition. This is nothing serious as the flame will burn out in a few seconds and will be followed by full brilliance. Remedy—Read and follow directions given in Paragraph 4.

NOTE— See suggestion F for other causes.

### B. IF LANTERN DOES NOT LIGHT AT ALL—

CAUSE—No fuel, lack of air pressure. Remedy—See that Fount contains clean fuel and then pump in 35 to 40 strokes of air into Fount.

CAUSE—Generator stopped up by dirt or carbon. Remedy—Put in complete new Generator.

### C. IF LIGHT GROWS DIM RAPIDLY OR GOES OUT SUDDENLY—

CAUSE—Fount may leak. Remedy—Pump up Fount and place in bucket of water to test for leak. If bubbles come from Filler Plug, put in new Filler Plug Gasket, or get a new Filler Plug complete. If bubbles come from around the bushing where Valve Body screws into Fount, be sure connection is tight. If leak continues send Lantern less Chimney and Ventilator to nearest Coleman Office.

### D. IF A LEAK DEVELOPS AT LOWER END OF GENERATOR—

CAUSE—Jamb Nut not threaded properly on Fuel Valve Body. Remedy—Close Fuel Valve. Then tighten Jamb Nut at bottom with Wrench. If leak continues, put on a new Jamb Nut. If new Jamb Nut fails to stop leaking, then trouble is with Fuel Valve Body, which should be replaced by new one.

### E. IF GENERATOR LASTS ONLY A SHORT TIME—

CAUSE—May be dirty gasoline. Remedy—Clean Fount thoroughly. Strain gasoline when filling Fount (see Paragraph 1).

### F. IF MANTLES TURN BLACK—

CAUSE—Air Intake Tube or Mixing Chamber may be stopped up. Remedy—Clean Air Intake Tube Mixing Chamber.

CAUSE—Dirty Burner Caps. Remedy—Unscrew Burner Caps and clean or replace with new ones.

CAUSE—Hole in Gas Tip may be enlarged. Remedy—Put on new Gas Tip.

CAUSE—Mantles used may be of inferior quality. Remedy—Always use Coleman Junior Mantles.

### G. IF BUILT-IN PUMP DOES NOT WORK—

CAUSE—Pump Leather may be dry. Remedy—Remove Pump Plunger and soften Pump Leather with oil.

CAUSE—Pump Leather worn out. Remedy—Put in new one.

CAUSE—Check Ball in Check Valve is stuck. Remedy—Unscrew Air Stem by turning Pump Plunger to left several turns—then unscrew Pump Cap and pull out Plunger and Air Stem. Insert screw driver in Pump Barrel, unscrew and remove Check Valve. Wash thoroughly in gasoline and replace. Insert Air Stem and Pump Plunger in Pump Barrel and screw on Pump Cap. If Pump still does not work, replace the Check Valve and Air Stem.

### H. IF WATER GETS MIXED WITH GASOLINE—

Clean Fount as outlined on other side. (See Paragraph 7).  
On one filling of two pints of gasoline the Lantern will provide an average of from 12 to 15 hours brilliant service. If directions for lighting and operating are followed.

## PARTS LIST FOR COLEMAN INSTANT-LIGHTING LANTERN MODEL NO. 228D

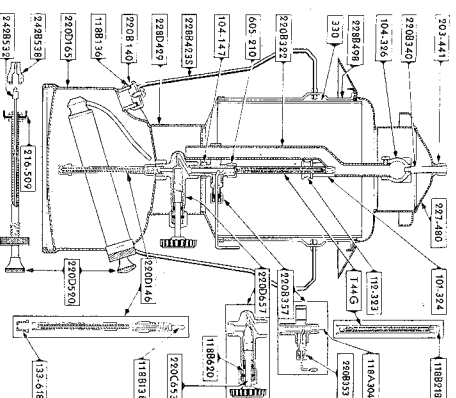

Parts No.	NAME OF PART	Net Retail Price
No. 0	Coleman Filter Funnel	\$ .75
21A	Jamb Nut (Gas Tip Marked "V")	2 for .25
T44G	Dozen	1.20

101-324	Lock Nut	.21
104-147	Burner Tube	.21
104-326	Mixing Chamber	.69
112-323	Burner Cap and Screen	.18
118A304	Eccentric Block	.09
118B136	Filler Plug Gasket	.03
118B138	Fuel Tip Cleaning Needle	.21
118B218	Gas Tip (Marked "V")	.09
118B620	Valve Stem (Packed)	.03
133-618	Fuel Tip (Marked "V")	.09
203-441	Ventilator Bolt Nut	.15
215-509	Pump Leather	.06
220B140	Filler Plug Complete	.69
220B322	Air Intake Tube	.69
220B340	Ventilator Tube	.15
220B353	Ventilator Rod	.15
220B357	Tip Cleaner Stem, Packed	.42
220B358	Gas Tip Cleaner Complete Assembled	.59
220C635	Wrench (Small)	.21
220D146	Valve Stem Complete	.89
220D155	Fuel and Air Wire Complete (Fuel Tip Marked "V")	6.00
220D520	Pump Complete	.81
220D520	Pump Plunger Complete (Less Air Stem)	2.40
227-480	Fuel Valve Complete	2.70
227-480	Ball	.21
228B423S	Frame and Ball	2.70
228B438	Base Rest	1.20
228D429	Air Stem	.27
242B532	Check Valve	.27
242B538	Pyrex Glass Globe	.27
330	Praxex Glass Globe	1.00
605-210	Jamb Nut	.09
605-550	Wrench (Large)	.21
No. 242D538	Check Valve can be unscrewed with an ordinary screw driver.	

Prices subject to change without notice.

Repair Parts in Canada Slightly Higher in Price on Account of the Customs Duty

## WARNING!

\*For longest service—for best service, use only Genuine Coleman Parts and Accessories on this Coleman Appliance. Each individual part is designed to exact precision and to work perfectly with all other parts; therefore, only Genuine Coleman Parts and Accessories can be trusted to give satisfactory service. The use of other than Genuine Coleman Parts and Accessories invalidates the Coleman Guarantee.

# OPERATING DIRECTIONS

for

# Coleman

## INSTANT-LIGHTING

## LANTERN

Model 228D

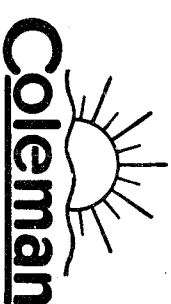

# Coleman

Made in the United States of America

## The Coleman Company, Inc.

General Offices and Factory: WICHITA 1, KANSAS, U.S.A.  
Canadian Office and Factory: Toronto, Canada  
Sales Offices: Chicago 11, Philadelphia 8, Los Angeles 54,  
Honolulu, Hawaii.

FT318B

Printed in U. S. A.

**Directions for  
Assembling and Operating**

**Coleman  
INSTANT-LIGHTING  
LANTERN  
Model 228D**

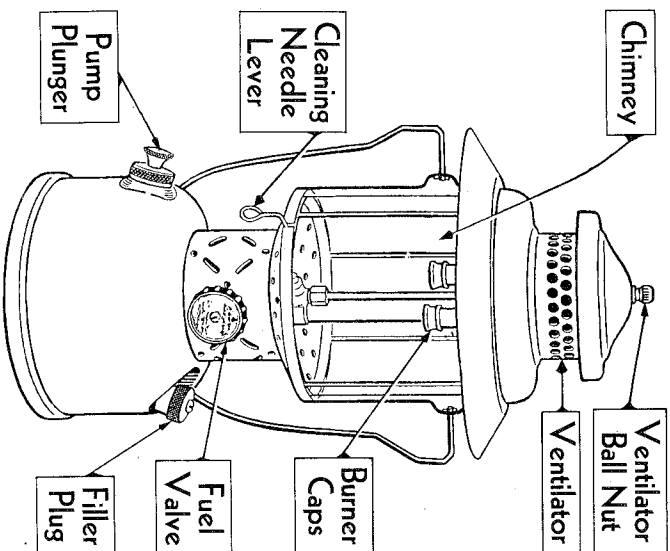

DO NOT USE DOPED, ANTI-KNOCK OR COLORED GASOLINES

**1. TO FILL—**

Be sure Fuel Valve is tightly closed to right. Then remove Filler Plug and fill Fount with two pints of fresh, clean, water-white, undoped gasoline (also known as "Petrol," "Motor Spirits," "Essence"). Do not tip Lantern while filling. Let it sit flat on its base. When filling the Fount strain the gasoline through several thicknesses of finely woven cloth. Or, better still, use the new Coleman Filtering Funnel, No. 0, which removes water and dirt from the gasoline. Your dealer can supply you. As soon as Fount is filled, replace Filler Plug and tighten firmly with fingers.

**2. TO PUMP—**

See that Fuel Valve is closed. Then open air Check Valve (inside of pump barrel) by turning Pump Plunger two full turns to left. Place ball of thumb over small hole in end of Pump Plunger and pump 35 to 40 full strokes of air into Fount. Now turn Pump Plunger to right, seating Air Stem in Check Valve, remove thumb and push Pump Plunger back into pump barrel.

Good Pressure is important. Keep Pump Leather soft with few drops of oil.

**3. TO PUT ON MANTLES—**

Unscrew Ventilator Ball Nut on top of Lantern, and remove Ventilator and Chimney. The mantles to grooves in Burner Caps with flat side of mantles parallel to Generator.

Distribute folds of mantles evenly at top and cut off surplus string.

Then burn off mantles following directions on mantle envelope. Allow mantles to cool several minutes before lighting Lantern.

**4. TO LIGHT—**

(a) At the base of the lantern frame you will note the Cleaning Needle Lever. When turned around this Lever causes the Gas Tip Cleaning Needle inside the Generator to work up and down. This keeps the Gas Tip clean and open. Turn the Lever several revolutions before lighting. Be sure the Lever is left pointing down.

(b) Have a match handy ready to light. Now open the Fuel Valve one-fourth turn. This is important—open it one-fourth turn only. Then light the match and hold it under the mantles. It may require a few seconds for the gas to reach the mantles but when it does mantles will light instantly. After the mantles burn bright open Fuel Valve as far as possible, which is about three full turns. This is important and must be done in order to get good light. It is impossible to open the Fuel Valve too far. After lighting Lantern pump in additional pressure to insure long operation.

The Cleaning Needle Lever may be operated while Lantern is burning. Should Lantern fail to burn bright after Fuel Valve is wide open, turn Cleaning Needle Lever rapidly two or three times.

NOTE—The light may flicker for a few seconds after lighting but it will soon steady down.

**5. TO TURN OUT LIGHT—**

Turn Fuel Valve to right until closed. The light will dim and go out in a few seconds.

**6. TO CHANGE GENERATORS—**

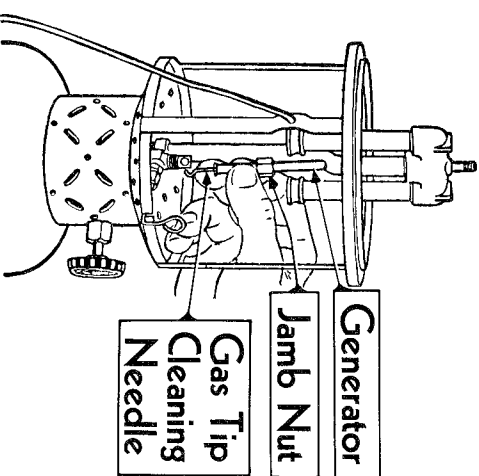

First be sure Fuel Valve is closed. Then turn Cleaning Needle Lever up. Unscrew Jamb Nut at lower end of Generator. Lift Generator up and unhook Gas Tip Cleaning Needle. Then pull Generator with Cleaning

Needle down and out. To install new Generator with Cleaning Needle: First pull Cleaning Needle down about 1". Place Cleaning Needle between forefinger and thumb, holding Generator in upright position. Push Generator through opening in Air Intake Tube, and hook Cleaning Needle in hole of Cleaning Block. Now turn Cleaning Needle Lever down, seat Generator properly. Screw Jamb Nut down, tightening with Wrench.

**7. KEEP FOUNT CLEAN—**

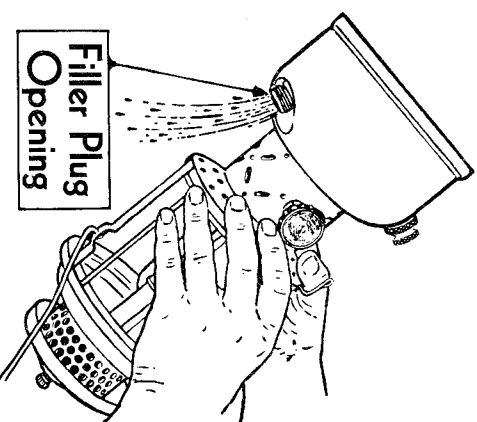

It is a good plan to drain the Fount each time before refilling. The Fount should be given a throo cleaning at least once a month. This removes yellow dirty gasoline and sediment which stops up the Generator and causes difficulty in operation. Simply remove the Filler Plug and drain fount thru Filler Plug Opening.

Your Lantern will light easier and better on fresh gasoline. A clean fount and the use of clean, water-white, undoped gasoline will help greatly to avoid generator stoppage and insure better light and better service.

Carefully following directions and using "Approved" gasoline will insure long and satisfactory service.