

② Quantity of Parts Used in Assembly

Parts List for COLEMAN LANTERN No. 202

17 - 058	Machine Screw	202 - 476	Screw
021A306	(21A) Mantle	202 - 484	Ventilator
118B1361	Gasket (Filler Plug)	202 - 489	Base Rest
200 - 1481	Tube Ass'y (Fuel and Air)	202 - 5201	Punger Ass'y (Pump)
200 - 3241	Tube (Burner)	202 - 6491	Wheel (Valve)
200 - 4561	Nut (Lock)	202 - 6531	Stem Ass'y
200A289	(T666D) Generator	202 - 6571	Valve (Less Generator)
200A3261	"J" Tube and Venturi	202 - 6621	Frame
202 - 1651	Fount (Complete)	202 - 6631	Bracket (Ventilator)
202 - 3531	Stem (Tip Cleaner)	203 - 441	Nut (Ball)
202 - 3701	Burner Ass'y (Complete)	216 - 509	Leather (Pump)
202 - 4231	Ball	220B1401	Filler Plug
		242 - 2181	Gas Tip (Marked 6)
		242 - 238	Needle Ass'y
		242 - 3041	Eccentric Block
		242 - 620	Packing (Valve Stem)
		242B5231	Cop (Burner)
		242B532	Stem (Air)
		242B5381	Check Valve
		252B619	Disc (Direction)
		530 - 452	Screw
		604 - 456	Nut (Hex - Cross)
		605 - 210	Jamb Nut
		690A051	(550) Globe



Filtering Funnel

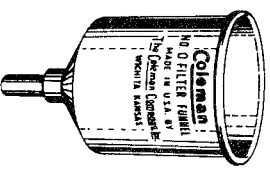

Most of the difficulty that users have with pressure gas lighting, heating, and cooking appliances is caused by dirty gasoline. Such a gas-line quickly stops up the generators and gas tips with the result that the appliance does not operate properly. Gasoline accumulates dirt and impurities in handling; and also water which is condensed in the storage tanks. All this foreign substance can be removed when the gasoline is strained through the new Coleman Filtering Funnel.

The No. 0 Funnel is well made of good material and has in the bottom a removable ring covered with a special filter fabric. When this fabric becomes saturated with gasoline, neither water nor dirt will pass through it. It is removable and can be cleaned by rinsing in fresh gasoline. Funnels are furnished in two sizes:

- No. 0 - Filtering Funnel, complete - Extra Pad for No. 0 Funnel
- No. 1A - Filtering Funnel, complete - Extra Pad for No. 1A Funnel

Listed below are the dimensions and capacity per minute of these two funnels.

No.	Diameter	Height	Outlet	Capacity per Min.
0	2 1/4 in.	3 1/2 in.	3/8 in.	1/2 Gal.
1	5 in.	6 in.	1/4 in.	4 Gals.

DIRECTIONS

for Operating

COLEMAN Instant-Lighting LANTERN

No. 202

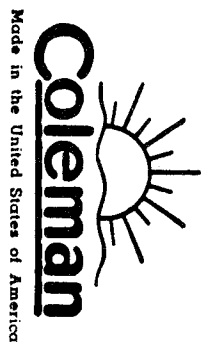

Made in the United States of America

The Coleman Company, Inc.

General Office and Factory: WICHITA 1, KANSAS, U. S. A.
 Canadian Office and Factory: Toronto, Canada
 Sales Offices: Philadelphia 40; San Francisco 3; Los Angeles 1

F6170 LITHO. IN. U. S. A.

How To Operate Your No. 202 Lantern

Always Use the Right Kind of Fuel

Those substances in gasoline which do not vaporize will collect in the generator in the form of carbon. The amount of service obtained from a generator depends, to a great extent, upon the kind of fuel used.

Always use clean, fresh, unleaded gasoline. Never use a gasoline containing lead compounds or lubricating oils. Keep gasoline supply in a small, clean, closed metal can. Do not use a glass container because of hazard in case of breakage. Gasoline exposed to light will sour in a short time.

If a suitable unleaded fuel is not available, then ask your service station operator to inquire of his company. Most oil companies make available a special stove and lighting fuel or naphtha for use in those localities where a suitable white gasoline is not available.

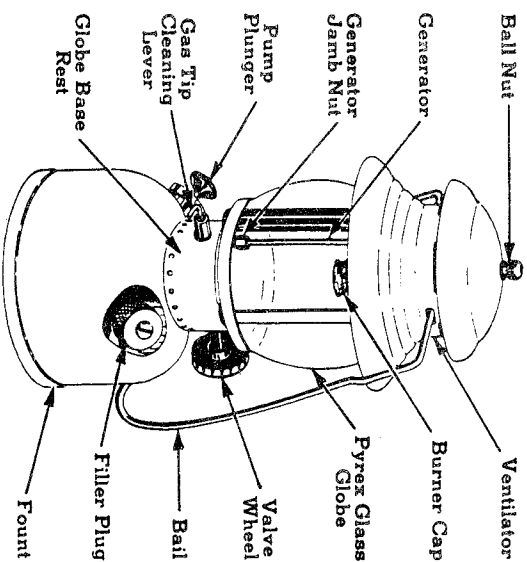

1. To Fill:

Be sure Fuel Valve is tightly closed by turning Valve Wheel to right. Remove Filler Plug and fill Fount with fresh, clean, untreated gasoline. Do not tip Lantern while filling. Always let it set flat on its base. We suggest the use of the Coleman Filtering Funnel for straining the gasoline. Your dealer can supply you. Fill fount—it holds 1 3/5 pints—then replace Filler Plug and tighten firmly with fingers.

2. To Pump Air Pressure Into Fount:

See that Fuel Valve is closed. Then open Air Check Valve inside of Pump Barrel by turning Pump Plunger two full turns to left. Place ball of thumb over small hole in end of Pump Plunger and pump 20 to 30 full strokes of air into Fount. Now, turn Pump Plunger to right until tight.

3. To Attach Mantle:

Unscrew Ball Nut from top of Lantern. Pull Bail out of Bail Sockets, remove Ventilator and Pyrex Glass Globe. Tie Mantle to groove in Burner Cap with flat side of Mantle parallel to Generator.

Distribute folds of Mantle evenly at top and cut off surplus string. Then burn off Mantle following directions on Mantle envelope. Allow Mantle to cool several minutes before lighting Lantern. Replace Pyrex Glass Globe, Ventilator and Bail. Be sure Bail is engaged in Bail Sockets. Then replace Ball Nut.

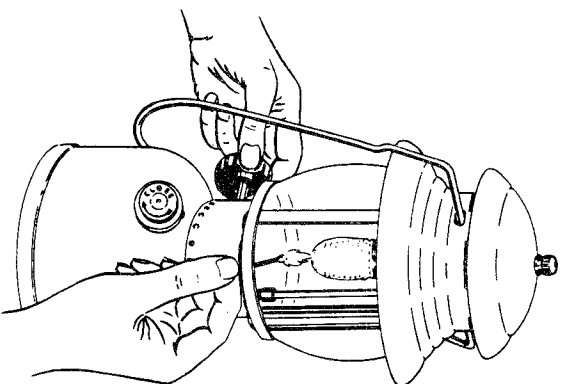

4. To Light:

(a) Rotate several times the Gas Tip Cleaning Lever which extends from under the Lantern Frame. This forces the point of the Cleaning Needle in and out of the Orifice in the Gas Tip at the end of the Generator to dislodge any

particles of carbon which may have collected in the Orifice. The Lever should be left pointing down.

(b) Have a match ready to light. Now, OPEN THE FUEL VALVE ONE-FOURTH TURN ONLY. Light the match, insert it through the lighter opening and hold it under the Mantle as shown in the illustration. A few seconds time may elapse before you will hear the mixture of gas and air feeding into the mantle but at that time the Mantle will light instantly. The light may flicker somewhat for a few seconds but as soon as Mantle burns bright open the Valve as far as possible. Unless you open the Valve all the way after the Lantern has been properly instant-lighted air pressure will continue to escape through the Valve and Generator.

5. To Turn Out Light:

Rotate several times, the Gas Tip Cleaning Lever. Turn Fuel Valve to right until closed. The light will dim and go out in a few seconds.

6. To Change Generator:

Remove Ventilator and Pyrex Globe. Unscrew hexagon nut No. 604-456 which holds Burner and Frame to Lantern. Carefully lift Burner and Frame up over Generator to avoid damage to the Mantle.

Turn Gas Tip Cleaning Lever up. Unscrew Generator Jamb Nut at lower end of Generator. Lift Generator up and unhook Gas Tip Cleaning Needle.

Pull end of Cleaning Needle down out of the new Generator far enough to hook into hole in Eccentric Block. After hooking Needle to Eccentric Block turn Gas Tip Cleaning Lever down. Next, slide Jamb Nut down over Generator and tighten with only enough force to prevent a leak at that point.

Be careful when placing Burner and Frame down over generator so Mantle will not be damaged. Replace and tighten hexagon nut to hold Frame and Burner in place.

7. Keep Fount Clean:

Rinse the Fount occasionally in order to prevent an excessive accumulation of sediment or moisture in the Fount. Contents of the Fount may be poured out through the Filler Plug Bushing.

8. Keep Burner Parts Clean:

Each time before installing a new Mantle use a bristle brush, such as a discarded tooth brush, to clean the Screen in the Burner Cap.

SUGGESTIONS

About Care and Use of Coleman Instant-Lighting Lantern No. 202

If Lantern Does Not Light, make sure there is plenty of air pressure and gasoline in Fount. Remove Generator Gas Tip to make sure that the point of the Needle has not been bent or curled. Open Valve slightly to make sure raw gasoline will come through Generator.

If Mantle Turns Black, make sure Burner Cap is clean and open. Check Air Intake Tube for a possible obstruction such as a spider's nest.

If Light Grows Dim, perhaps Valve has not been opened all the way after Lantern has been instant-lighted. Rotate Cleaning Lever on side of Valve to remove carbon, if any, from Orifice in Generator Gas Tip.

If Light Has a Tendency to Pulsate or flicker slightly after a new Generator has been installed, then pump additional air pressure into the Fount until the situation is corrected.

The Pump Plunger is not only used for pumping air pressure into the Fount but it acts as a wrench to turn the Air Stem. Turning the Plunger to the left unscrews the Air Stem so that air may be forced through the Check Valve at the bottom of the Pump Barrel. Turning the Pump Plunger to the right screws the Air Stem into the Check Valve to provide a positive shut-off at that point. Air pressure may be added while the Lantern is burning. Oil the leather occasionally for greater efficiency.

If Lantern Is To Be Left Unused for several days or weeks, it would be well to empty the gasoline from the Fount. This would prevent the gasoline from souring and forming gum in the Fount.

If Lantern Is To Be Kept On Hand for standby emergency use in case of storm or power line failure, then empty all gasoline from the Fount and after Fount has cooled, refill with clean, fresh gasoline. Keep Lantern in as cool a place as possible.

To Test Ball-In Pump for an air pressure leak, tip the Fount over so you can hold the end of the Pump in a full glass of water.

If You Have Occasion to Write the dealer or the factory, mention the model number of your Lantern as a No. 202.

If You Have to Mail the Lantern in for Service Attention, then send it less the Pyrex Globe and Ventilator to avoid breakage.